

Magnetic Sensor ICs

Omnipolar Detection High Performance Low Power 3D Hall-Effect Sensor IC

**AS1190C**

● General Description

Using low power CMOS process, the AS1190C is designed for low power, high performance omnipolar detection 3D hall-effect application. The 3D hall IC integrated an on-chip hall voltage generator for magnetic sensing, a comparator that amplifies the hall voltage, a Chopper amplifier, a Schmitt trigger to provide switching hysteresis for noise rejection, and a complementary output.

The total power consumption of AS1190C is typically less than 1.3uA at 1.8V power supply. AS1190C is designed to respond to alternating North and South poles. When the magnetic flux density (B) is larger than operate point (B_{OP}), the output will be turned on (low), the output is held until the magnetic flux density (B) is lower than release point (B_{RP}), then turn off (high).

The device is available in SOT23-3L Package and is rated over the -40°C to 125°C . The all packages are RoHS and Green compliant.

● Features

- 3D (X, Y, Z) Magnetic Flux Switch
- Omnipolar Operation, easy to use as output
- Input Voltage Range : 1.65V to 5.5V
- Micro-power consumption ideal for battery power applications: 1.3uA/1.8V
- Very high sensitivity hall sensor
- Low Power CMOS process technology
- Chopper stabilization amplifier stage
- High Magnetic Sensitivity
- Good RF noise immunity
- No need pull-up resistor
- Small Solution Size
- RoHS & Green Compliant
- SOT23-3L Packages
- -40°C to $+85^{\circ}\text{C}$ Temperature Range

● Applications

- Smart Meter
- Cover switch
- Contact-less switch
- Air Cylinder, Antitheft window, Digital door lock
- Water Purifier, Humidifier Bidet
- Water Meter, Gas Meter, Wattmeter etc
- Washing Machine, Rice Cooker, Refrigerator, Electronic Dictionary, Digital Camera etc

■ **Ordering Information**

AS1190CXXX

Package: ST: SOT23-3L Packing: R: Tape&Reel Temperature Grade:
 N: -40°C~85°C
 Y: -40°C~125°C

Part Number		B _{OP} (Gauss)	B _{RP} Gauss)	Package Type	Package Qty	Temperature	Eco Plan
AS1190CSTRN	X/Y	±22	±15	SOT23-3L	7-in reel 3000pcs/reel	-40~85°C	Green
	Z	±10	±7				
	Z	±10	±7				
AS1190CSTRY	X/Y	±22	±15	SOT23-3L	7-in reel 3000pcs/reel	-40~125°C	Green
	Z	±10	±7				
	Z	±10	±7				

■ **Marking & Pin Assignment**

SOT23-3L:

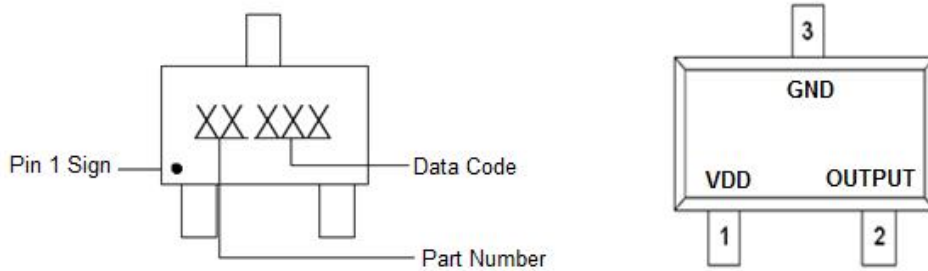

Pin Name	Pin No.	I/O	Pin Function
	SOT23-3L		
VDD	1	P	Input Power Supply
GND	3	P	Ground
OUTPUT	2	O	Output Pin

■ **Typical Application Circuit**

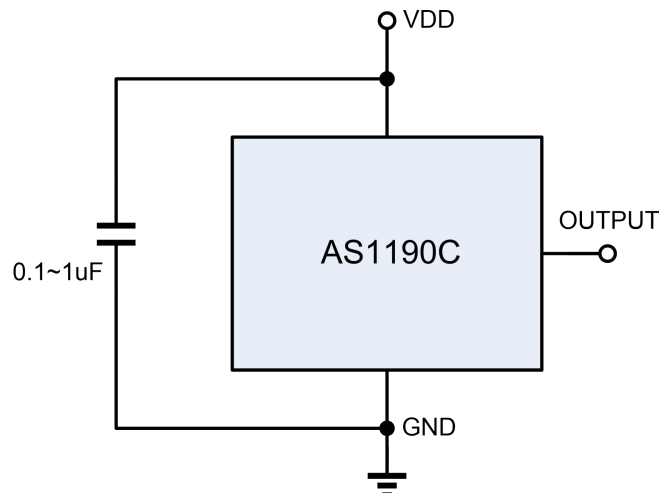

Figure 1, Typical Application Circuit of AS1190C

■ Block Diagram

Figure 3, Block Diagram of AS1190C

■ Absolute Maximum Ratings¹ ($T_A=25^\circ\text{C}$, unless otherwise noted)

Parameter	Symbol	Rating	Unit
V_{DD} Pin to GND	V_{DD}	-0.3 to 6.0	V
Output Pin to GND	V_{OUTPUT}	-0.3 to $V_{DD} + 0.3$	V
Max. Continuous Output Current	I_{OUTMAX}	2.0	mA
Package Power Dissipation	SIP-3L	P_D	250
	SOT23-3L	P_D	180
ESD (HBM)	ESD	8000	V
Operating Junction Temperature Range	T_{OP}	-40 to +150	$^\circ\text{C}$
Maximum Soldering Temperature (at leads, 10 sec)	T_{LEAD}	300	$^\circ\text{C}$

■ Recommended Operating Conditions²

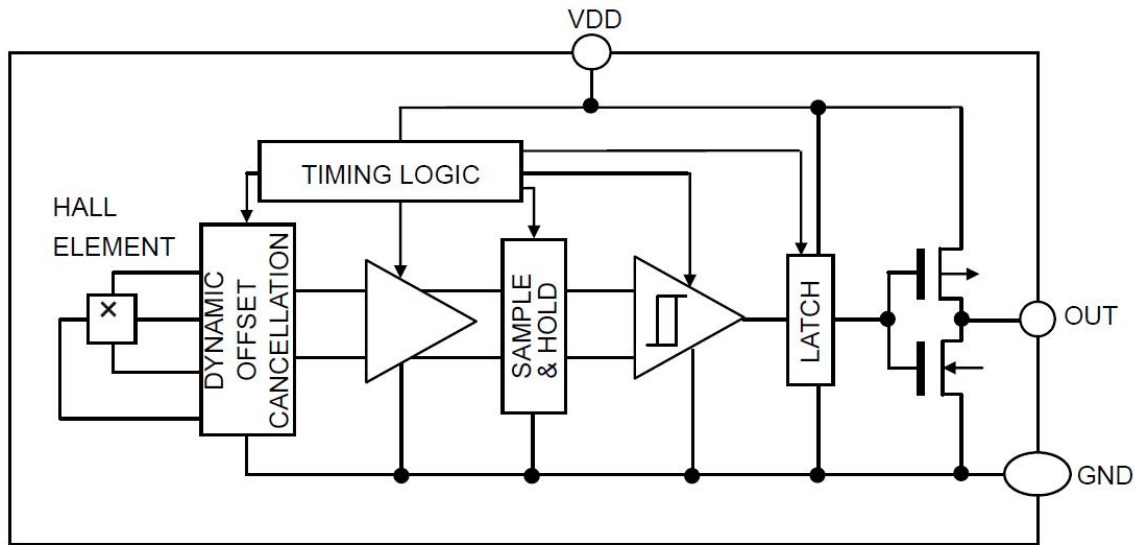
Parameter	Symbol	Rating	Unit
V_{DD} Pin to GND	V_{DD}	1.65 to 5.5	V
Continuous Output Current	I_{OUT}	1.0	mA
Operating Temperature Range	T_{OP}	-40 to +85	$^\circ\text{C}$

Note: 1: Stresses above those listed in absolute maximum ratings may cause permanent damage to the device. Functional operation at conditions other than the operating conditions specified is not implied. Only one absolute maximum rating should be applied at any one time.

2: The device is not guaranteed to function outside of its operating conditions.

■ Electrical Characteristics

($T_A = -40$ to $+85^\circ\text{C}$ unless otherwise noted. Typical values are at $T_A = +25^\circ\text{C}$, $V_{DD} = 1.8\text{V}$) (1mT=10Gauss)

Symbol	Parameter	Conditions	Min.	Typ.	Max.	Unit
V_{DD}	Input Voltage		1.65	3.6	5.5	V
$I_{DD(AVG)}$	Supply Current	Average supply current, $T_A = 25^\circ\text{C}$, $V_{DD} = 1.8\text{V}$	-	1.3	3.0	μA
$I_{DD(AVG)}$		Average supply current, $T_A = -40 \sim 85^\circ\text{C}$, $V_{DD} = 1.65 \sim 5.5\text{V}$	-	2.0	5.0	μA
T_{awake}	Awake Time		-	100	150	μs
T_{period}	Period		-	100	150	ms
D.C.	Duty Cycle		-	0.05	-	%
V_{OH}	Output Off Voltage (High side)	$I_{OUT} = +1\text{mA}$	$V_{DD} - 0.3$	$V_{DD} - 0.1$	$V_{DD} + 0.3$	V
V_{OL}	Output On Voltage (Low side)	$I_{OUT} = -1\text{mA}$	-0.3	0.1	+0.3	V

■ **Electrical Characteristics**

($T_A = -40$ to $+85^\circ\text{C}$ unless otherwise noted. Typical values are at $T_A = +25^\circ\text{C}$, $V_{DD} = 1.8\text{V}$) (1mT=10Gauss)

Symbol	Parameter	Conditions	Min.	Typ.	Max.	Unit
Magnetic Para. (X and Y-Axis)						
B _{OPS}	Magnetic Operating Point		-	22	45	Gauss
B _{OPN}			-45	-22	-	
B _{RPS}	Magnetic Release Point		5	15	-	Gauss
B _{RPN}			-	-15	-5	
B _{HYS}			-	7	-	Gauss
Magnetic Para. (Z-Axis)						
B _{OPS}	Magnetic Operating Point		-	10	25	Gauss
B _{OPN}			-25	-10	-	
B _{RPS}	Magnetic Release Point		3	7	-	Gauss
B _{RPN}			-	-7	-3	
B _{HYS}	Hysteresis Window		-	3	-	Gauss

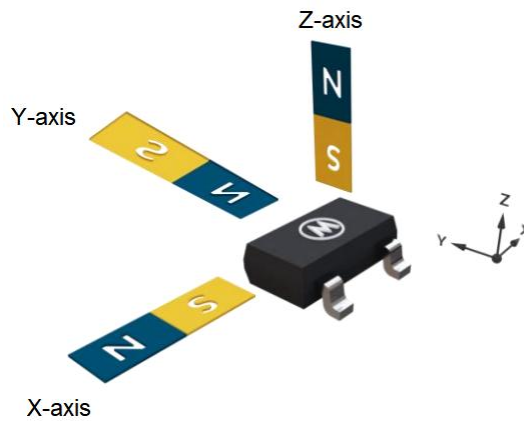

Fig 4A, 3D (X/Y/Z-Axis) Magnetic Operation of AS1190C

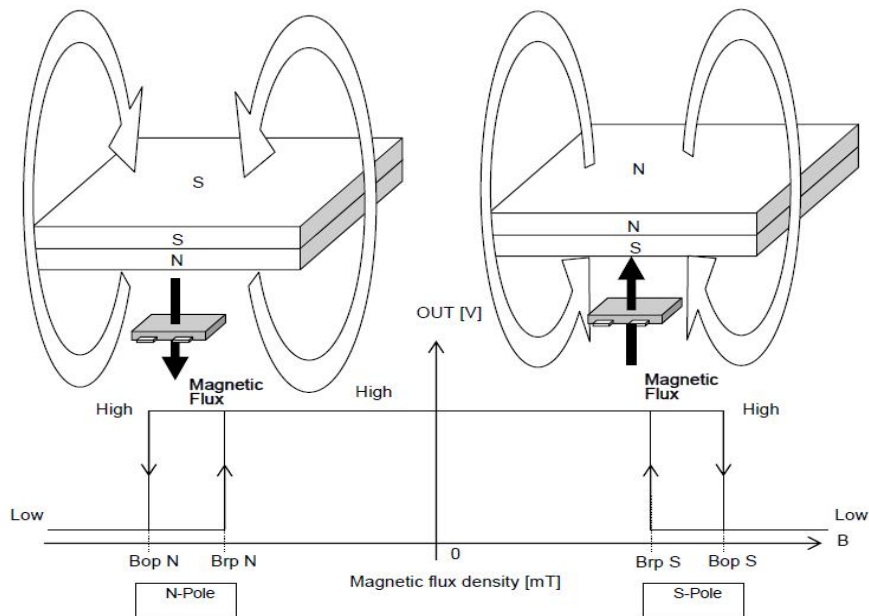
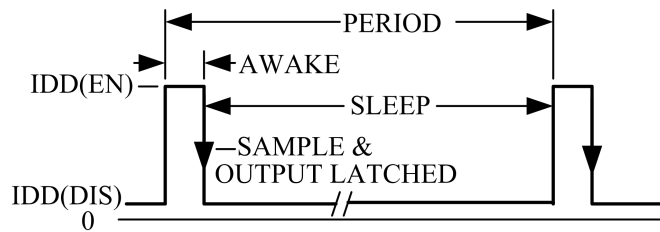

Fig 4B, Z-Axis Magnetic Operation Characteristic of AS1190C

■ **Function Description**



Micro-power Operation

Internal timing circuitry activates the sensor for 50 μ s and deactivates it for the remainder of the period (100ms). A short "awake" time allows for stabilization prior to the sensor sampling and data latching on the falling edge of the timing pulse. The output during the "sleep" time is latched in the last sampled state. The supply current is not affected by the output state.

Chopper-Stabilized Technique

The 3D Hall element can be considered as a resistor array similar to a Wheatstone bridge. A large portion of the offset is a result of the mismatching of these resistors. These devices use a proprietary dynamic offset cancellation technique, with an internal high-frequency clock to reduce the residual offset voltage of the Hall element that is normally caused by device over-molding, temperature dependencies, and thermal stress. The chopper-stabilizing technique cancels the mismatching of the resistor circuit by changing the direction of the current flowing through the Hall plate using CMOS switches and Hall voltage measurement taps, while maintains the Hall voltage signal that is induced by the external magnetic flux. The signal is then captured by a sample-and-hold circuit and further processed using low-offset bipolar circuitry. This technique produces devices that have an extremely stable quiescent Hall output voltage, are immune to thermal stress, and have precise recoverability after temperature cycling. A relatively high sampling frequency is used for faster signal processing capability can be processed.

Operation

The output of this device switches low (turns on) when a magnetic field perpendicular to the Hall sensor exceeds the operate point B_{OPS} (or is less than B_{OPN}). After turn-on, the output is capable of sinking up to 1mA and the output voltage is $V_{OUT(ON)}$. When the magnetic field is reduced below the release point B_{RPS} (or increased above B_{RPN}), the device output switches high (turns off). The difference between the magnetic operates and release points are the hysteresis (B_{hys}) of the device. This built-in hysteresis allows clean switching of the output even in the presence of external mechanical vibration and electrical noise.

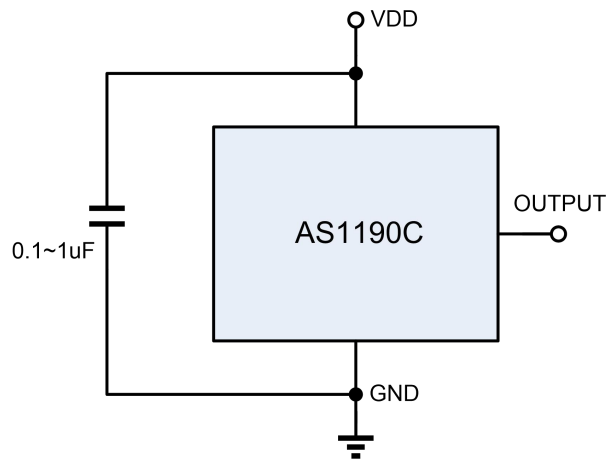
■ Applications:

AS1190C's pole-independent sensing technique allows for operation with either a north or south poles magnet orientation, enhancing the manufacturability of the device. The state-of-the-art technology provides the same output polarity for either pole face.

C1 serves two purposes: minimizing ripples on the input voltage and enhancing immunity from RF transmission noises within close proximity. Recommended values are between 10nF and 100nF. The larger the capacitance, the better the noise immunity is for the AS1190C.

It is strongly recommended that an external bypass capacitor be connected (in close proximity to the Hall sensor) between the supply and ground of the device to reduce both external noise and noise generated by the chopper-stabilization technique. This is especially true due to the relatively high impedance of battery supplies. The simplest form of magnet that will operate these devices is a bar magnet with either pole near the branded surface of the device.

Thermal Considerations

The maximum IC junction temperature should be restricted to 125°C under normal operating conditions. This restriction limits the power dissipation of the AS1190C. Calculate the maximum allowable dissipation, $P_{D(max)}$, and keep the actual dissipation less than or equal to $P_{D(max)}$. The maximum-power-dissipation limit is determined using following equation:

$$P_{D(MAX)} = \frac{125^{\circ}\text{C} - T_A}{R_{\theta JA}}$$

Where, T_A is the maximum ambient temperature for the application. $R_{\theta JA}$ is the thermal resistance junction-to-ambient given in Power Dissipation Table.

■ Package Information

SOT23-3L:

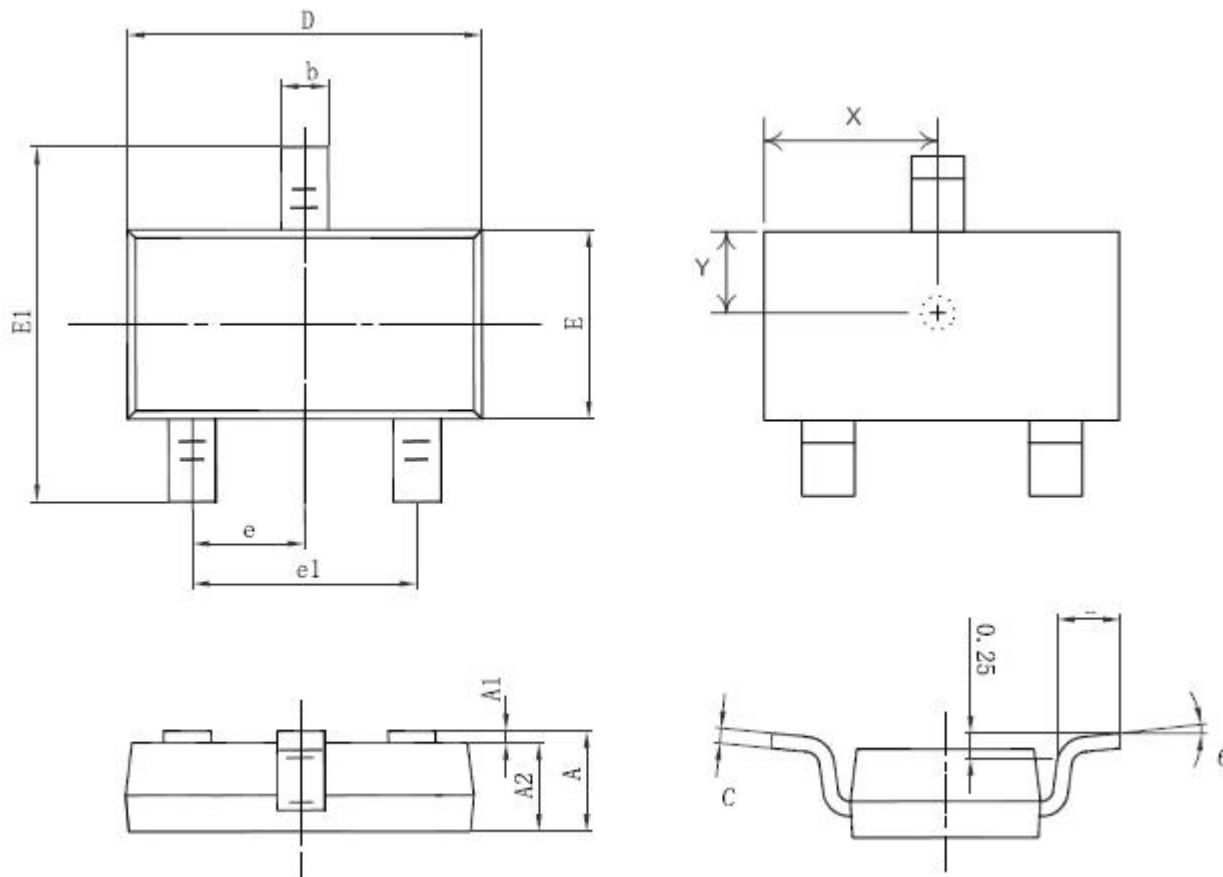

Symbol	Dimensions In Millimeters		Dimensions In Inches	
	Min.	Max.	Min.	Max.
A	1.050	1.250	0.028	0.035
A1	0.000	0.100	0.000	0.004
A2	1.050	1.150	0.028	0.031
b	0.350	0.500	0.014	0.020
c	0.080	0.200	0.003	0.008
D	2.820	3.020	0.111	0.119
E	1.600	1.700	0.063	0.067
E1	2.650	2.950	0.104	0.116
e	0.950(BSC)		0.037(BSC)	
e1	1.900(BSC)		0.075(BSC)	
L	0.300	0.600	0.012	0.024
θ	0°	8°	0°	8°
X	1.410	1.510	0.056	0.059
Y	0.800	0.850	0.031	0.033

■ Packing Information

SOT23-3L:

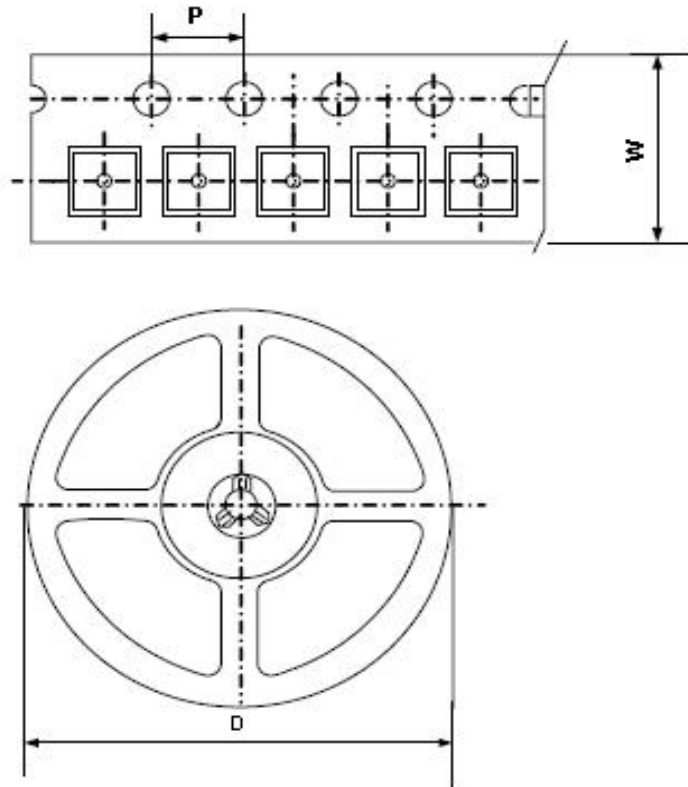

Package Type	Carrier Width(W)	Pitch(P)	Reel Size(D)	Packing Minimum
SOT23-3L	8.0±0.1 mm	4.0±0.1 mm	180±1 mm	3000pcs

Note: Carrier Tape Dimension, Reel Size and Packing Minimum